

# KOMATSU®

## 960E-1

**GROSS HORSEPOWER**

2610 kW **3,500 HP**

**NOMINAL GVW**

576072 kg **1,270,000 lb**

**960E**

**ELECTRIC DRIVE TRUCK**



Photos may include optional equipment

# WALK-AROUND

## *Productivity Features*

- High performance Komatsu SSDA18V170 engine  
Gross horsepower 2610 kW **3,500 HP**
- GE dual IGBT AC electric drive system
- 6,000 HP continuous retarding capability
- Automatic retard speed control
- Traction (spin/slide) control
- Application specific body designed to hold rated payload (optional)
- Tight turning radius 16 m **52'6"**
- Payload Meter III (standard)

## *Environmentally Friendly*

- Komatsu SSDA18V170 engine is compliant with US EPA emissions regulations
- Lead-free radiator design
- Fuel efficient engine with 2-stage turbocharging

## *Reliability Features*

- Frame structurally enhanced for 327 ton **360 short ton** payload
- Proven wheelmotor design
- Simple and reliable hydraulic system
- Fully-hydraulic controlled multiple-disc wet brakes
- Steering and brake accumulators



**GROSS HORSEPOWER**  
2610 kW 3,500 HP @ 1900 rpm

**NOMINAL GVW**  
576072 kg 1,270,000 lb

### ***Operator Environment***

- Ergonomically designed spacious cab with excellent visibility
- Ideal driving position settings
- Hydropneumatic suspensions designed for all terrain
- Four post ROPS/FOPS Level 2
- Simplified dash panel with payload display
- Multiple-disc wet brakes and fully hydraulic braking system



### ***Easy Maintenance***

- Vehicle Health Monitoring System (VHMS) with PLM III and ORBCOMM
- Integrated VHMS allows immediate diagnostics of key engine and drive system components
- Fully hydraulic braking system reduces wear and improves replacement intervals
- Extended oil change intervals based on the Centinal system
- Automatic lubrication system
- Flange-type tire rims

# PRODUCTIVITY FEATURES

## Komatsu SSDA18V170 High Horsepower Engine

Komatsu's new SSDA18V170 engine was designed and developed by the Industrial Power Alliance (IPA) technical joint venture between Komatsu and Cummins. This 2610kW **3,500 HP** engine will operate in today's mining applications without power derate. Fuel efficiency is maximized due to optimized air handling with 2-stage turbocharging. A standard pre-lube system is designed to eliminate start-up wear and increase overhaul life. Standard features include:

- CENSE® on board monitoring of engine performance for each cylinder
- CENTINEL® Advanced Engine Oil Management System
- ELIMINATOR® filtration system reduces oil and filter changes by one third



## 6,000 Horsepower Continuous Retarding Capability

The 6,000 HP retarding system provides state of the art braking capacity for navigating today's mining applications which contain steep continuous descents and sharp switchbacks.

Continuous retarding capacity enhances the productivity and confidence of the vehicle operator, while eliminating the need for excessive mechanical braking effort.



## GE Dual IGBT AC Electric Drive System

Invertex® AC control system offers independent control of the rear wheelmotors, which in turn provides outstanding traction-ability during wet and slippery conditions, thus improving tire wear and operator confidence.

The air cooled Insulated Gate Bipolar Transistor (IGBT) inverter system technology provides the highest available reliability. The IGBT inverter is more compact and much simpler than the design of its predecessor, the Gate Turn Off (GTO) inverter, which improves serviceability and routine maintenance.



### Traction (Spin-Slide) Control

During slippery events caused by inclement weather conditions and/or application severity, the 960E wheel Slip-Slide prevention technology will detect and correct any wheel spin control events. Slip-Slide Control operates automatically and independently of the service brakes. During propulsion, "wheel slip control" reduces non-productive wheel spin in low traction conditions. During retarding, "wheel slide control" prevents wheel lockup and subsequent sliding.

### Automatic Retard Speed Control

While in continuous descent, the operator has the capability to select a comfortable downhill travel speed. Automatic Retard Speed Control simultaneously manages the speed of each wheel independently to allow for any immediate adjustments needed during slippery underfoot conditions.

### Application Specific Body

For all trucks, Komatsu goes through the Body Application Worksheet (BAW) process to ensure that each body is designed to meet the requirements for each specific application while carrying its rated payload. Komatsu works with each customer to understand all of the material properties at a mine site and to identify the appropriate liner package.

Komatsu offers a standard all-welded steel, flat floor body with a full canopy and horizontal bolsters. This body includes a driver side eyebrow, rear wheel rock ejectors, body up sling, and rubber mounts on the frame.

- Standard Body Struck Capacity: 149 m<sup>3</sup> **195 yd<sup>3</sup>**
- Standard Body SAE Heaped 2:1: 214 m<sup>3</sup> **280 yd<sup>3</sup>**
- Standard Komatsu Body Weight: 40823 kg **90,000 lbs**



## Tight Turning Radius

By using double acting hydraulic steering cylinders with a six-point articulation linkage, the 960E-1 power steering system provides positive steering control with minimal operator effort. The turning circle has a diameter of 32 m **105 ft** which meets SAE J1511 standards. Nitrogen charged accumulators will automatically provide power in the event that hydraulic pressure drops below an acceptable minimum.

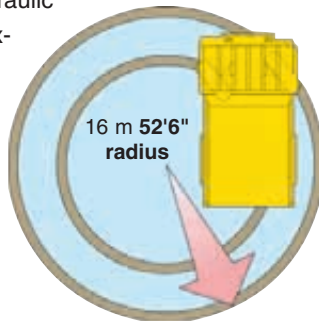

## Payload Meter III

PLM III is an electronic system that monitors and records payload information for Komatsu's family of Off-Highway Mining Trucks. The improved accuracy of payload measurement and reliability of the system are designed to optimize payloads, maximize productivity, and reduce the life cycle costs of the truck. PLM III tracks and records the following key production parameters:

- Payload
- Empty Carry-Back (Loaded and Empty)
- Operator I.D.
- Haul Cycle, Loading, Dumping Time of Day
- Distance Traveled (Loaded and Empty)
- Peak Positive and Negative Frame Torque
- Cycle Time Information
- Peak Sprung Load with Time of Day
- Maximum Speeds (Loaded and Empty)
- TMPH for Front and Rear Tires
- Average Speed (Loaded and Empty)

## Example of Payload Summary

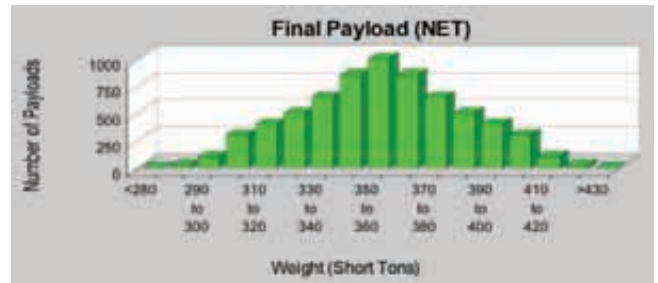

# OPERATOR ENVIRONMENT

## Ergonomically Designed Cab

The Komatsu 960E-1 cab design ensures that the operator is comfortable and confident during routine operation, thus providing a productive environment to meet the needs of today's mining demands. The cab includes tinted safety glass windows, heating and air conditioning, acoustical insulation, double sealed doors, and filtered, pressurized air for a virtually dust-free atmosphere.

## Built-in ROPS and FOPS Structure

These structures conform to mining regulations.

## Hydropneumatic Suspensions

Hydrair II suspension cylinders located at each wheel provide a smooth and comfortable ride for the operator and dampen shock loads to the chassis during loading and operation.

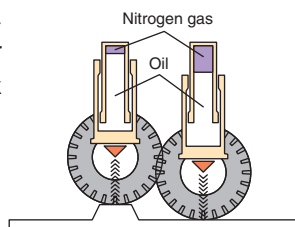

## Ideal Driving Position Settings

The 5-way adjustable operator seat and the tilt-telescopic steering column provide an optimum driving posture for increased driving comfort and more control over machine operation. The suspension seat dampens vibrations transmitted from the machine and reduces operator fatigue as well as holding the operator securely. A 78mm 3" wide seat belt is provided as standard equipment.



Photo includes optional equipment



# RELIABILITY FEATURES

## Steering and Brake Accumulators

In the event that the hydraulic pressure in the steering or braking system drops below an acceptable minimum, nitrogen-charged accumulators will automatically apply the brakes so that the truck may be stopped. There are separate accumulators for the braking and steering systems.



## Simple and Reliable Hydraulic System

The hydraulic system is a proven and reliable design with fewer parts than other OEMs. The system utilizes a common tank, and therefore, common fluid for steering, braking, and hoisting. In-line, replaceable filtration elements provide additional hydraulic system protection from contamination.



## Structurally Enhanced Frame Design

By using advanced computer-aided design, finite element analysis, and full-scale dynamic and static testing, the frame design has been structurally enhanced to carry 327 t **360 short tons** and provide the highest reliability in the industry.

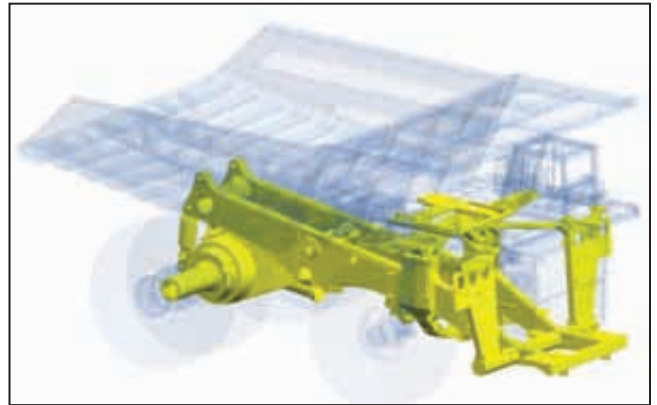

## Proven Wheelmotor Design

The GDY108 has a redundant brake and transmission fluid sealing arrangement for better reliability and an improved oil drain system for easier maintenance.

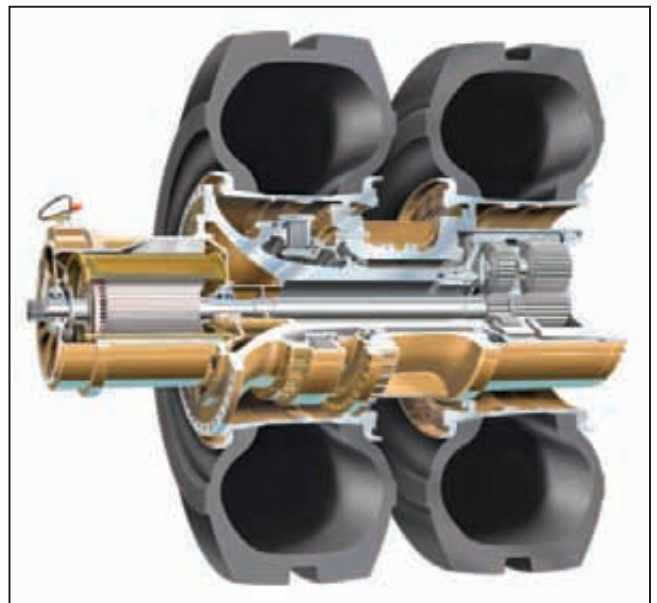

### Fully Hydraulic Controlled Multiple-Disc Wet Brakes

Although the dynamic retarding system is the primary braking force, the 960E-1 comes standard with four-wheel, hydraulically actuated, oil cooled service brakes. In the event that the truck's hydraulic system pressure drops below an acceptable level, accumulator tanks will automatically apply all wheel brakes to bring the truck to a complete stop.

- Max. service apply pressure: 18960 kPa **2,750 psi**
- Total friction area per brake: 103729 cm<sup>2</sup> **16,078 in<sup>2</sup>**

The oil cooled brake system provides lower maintenance costs and higher reliability versus dry disc brakes. This system is fully sealed to help keep contaminants out and reduce brake wear and maintenance. The brakes are hydraulically actuated, removing all air from the design. By eliminating an air system, air bleeding is not required and water condensation that can lead to contamination, freezing, and corrosion is no longer present. There are three independent hydraulic circuits that provide hydraulic back-up.



# EASY MAINTENANCE

## Advanced Monitoring System – On-board Diagnostics

The Komatsu advanced monitoring system identifies maintenance items to the operator, reduces diagnostic times, indicates oil and filter replacement hours, and displays fault codes. This monitoring system is designed to maximize machine availability.

## Automatic Lubrication System

The automatic lubrication system is designed to reduce downtime for lubrication by having a centralized location that automatically distributes grease to all lubrication points.



## Extended Oil Change System

Cummins CENTINEL® oil management system and ELIMINATOR® filtration system reduce oil and filter changes by one third. Oil drain is extended to 4,000 hours, and there are no spin-on oil filters. Centrifuge paper is replaced every 1,500 hours.

## Vehicle Health Monitoring System (VHMS) with ORBCOMM

The VHMS controller monitors the health conditions of all major components and enables remote analysis of the machine and its operation. VHMS can be monitored by downloading information directly from the truck with a laptop, or through the use of ORBCOMM, a satellite communication network, that allows access to the machine conditions through the internet.

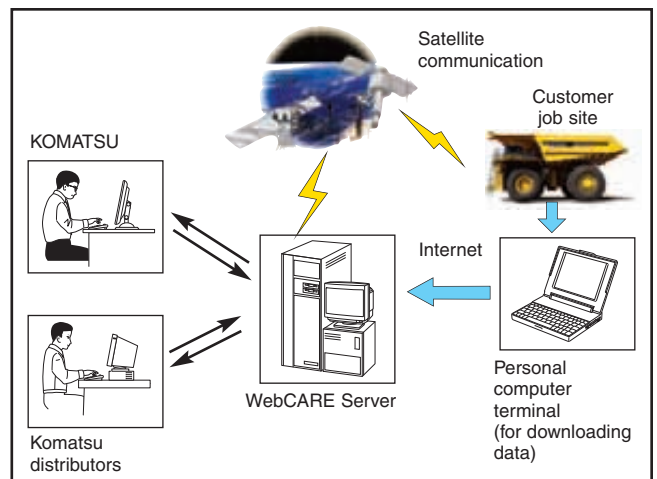

## Flange Type Tire Rims

The flange type rims allow easy removal and installation of the tires and minimize the overall impact on downtime.



# ADDITIONAL FEATURES

## Environmentally Friendly

### Komatsu SSDA18V170 Engine

The Komatsu SSDA18V170 is compliant with the U.S. EPA emissions regulations.

### Lead-Free Radiator

In addition to compliance with emission regulations, a lead-free aluminum core is used for the radiator to meet global environmental requirements.

### Dynamic Retarding Whispergrids (Optional)

For low noise requirements, the dynamic retarding resistor grids may be fitted with Whispergrids which are designed to reduce the noise level produced when the retarding system is activated.

### Selectable Stairway Direction



Komatsu's 960E-1 offers stairway access with entry from either the right or left side of the truck depending on the customer's preference.

## Payload Policy

Recognizing that variation occurs naturally in material density, fill factors, and loading equipment, Komatsu America Corp. deems it necessary to establish a consistent loading policy for the 960E-1. This loading policy is intended to identify the guidelines and limitations for the loading of Komatsu Mining Trucks, and is valid for approved applications and haul profiles only.

### 10-10-20 Load Policy Criteria

- 1) 10% of all loads may be between 110% and 120% of the rated payload of the truck
- 2) 90% of all loads must be below 110% of the rated payload of the truck
- 3) The average monthly payload must not exceed the rated payload of the truck
- 4) No single payload may exceed 120% of the rated payload of the truck

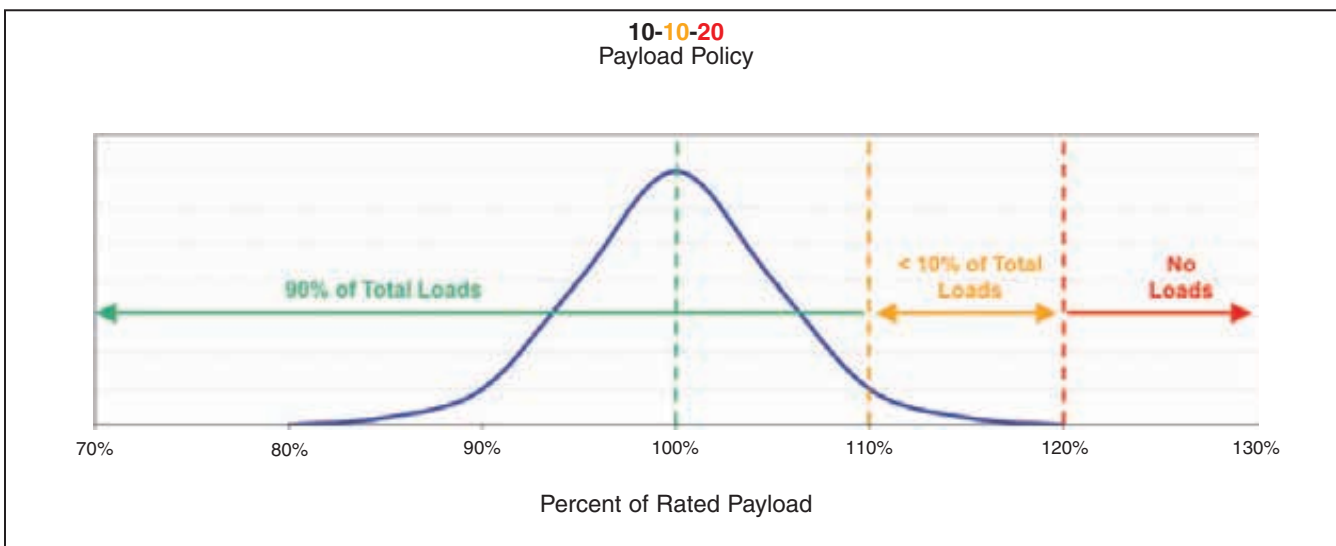

# SPECIFICATIONS



## ENGINE

Make and model	Komatsu SSDA18V170
Fuel	Diesel
Number of cylinders	18
Operating cycle	4 cycle
Gross horsepower*	2610 kW <b>3,500 HP</b> @ 1900 rpm
Net flywheel power**	2495 kW <b>3,346 HP</b> @ 1900 rpm
Weight (wet)	10340 kg <b>22,795 lb</b>

\* Gross horsepower is the output of the engine as installed in this machine, at governed rpm and with engine manufacturer's approved fuel setting. Accessory losses included are water pump, fuel pump and oil pump.  
 \*\* Net flywheel power is the rated power at the engine flywheel minus the average accessory losses. Accessories include fan and charging alternator. Rating(s) represent net engine performance in accordance with SAE J1349 conditions.



## ELECTRIC DRIVE

AC/DC CURRENT	
Alternator	GTA-39
Dual impeller in-line blower	340 m <sup>3</sup> /min <b>12,000 cfm</b>
Control	AC Torque Control System
Motorized wheels*	GDY108 Induction Traction Motors
Ratio	32.62:1
Speed (maximum)	64.5 km/h <b>40 mph</b>

\* Wheel motor application depends upon gross vehicle weight, haul road grade, haul road length, rolling resistance and other parameters. Komatsu and G.E. must analyze each job condition to assure proper application.



## TIRES AND RIMS

Rock service, tubeless, radial tires	
Standard tire*	56/80 R63
Flange mount rim	
1041 mm x 1600 mm x 140 mm	<b>41" x 63" x 5.5"</b> rim assembly.
Rims rated at 758 kPa	<b>110 psi</b> cold inflation pressure.
Typical tire weight	29553 kg <b>65,154 lb</b>

\* Tires should meet application requirements for tkph/tnph, tread, compound, inflation pressure, ply rating or equivalent, etc.



## BODY

All-welded steel flat floor body with horizontal bolsters and full canopy. Eyebrow, rear wheel rock ejectors, body up sling and rubber mounts on frame are standard. Pivot exhaust heating optional.

Floor sheet	16 mm <b>0.63"</b> Outer
	19 mm <b>0.75"</b> Center
	1379 MPa <b>200,000 psi</b> tensile strength steel
Front sheet	10 mm <b>0.39"</b> Outer
	12 mm <b>0.47"</b> Center
	1379 MPa <b>200,000 psi</b> tensile strength steel
Side sheet	10 mm <b>0.39"</b>
	1379 MPa <b>200,000 psi</b> tensile strength steel
Canopy sheet	6 mm <b>0.24"</b>
	.690 MPa <b>100,000 psi</b> tensile strength steel
Capacity struck	.149 m <sup>3</sup> <b>195 yd<sup>3</sup></b>
SAE heaped 2:1	.214 m <sup>3</sup> <b>280 yd<sup>3</sup></b>
Standard Komatsu body weight	40823 kg <b>90,000 lb</b>



## CAB

Advanced Operator Environment with integral 4-post ROPS/FOPS Level 2 structure, adjustable air suspension seat w/lumbar support and arm rests, full-size passenger seat, maximum R-value insulation, tilt and telescoping steering wheel, electric windshield wipers w/washer, tinted safety glass, power windows, Komatsu Payload Weighing System, 55,000 Btu/hr **11,891 ft-lbs/sec** heater and defroster, 21,600 Btu/hr **4,670 ft-lbs/sec** air conditioning (HFC - 134A refrigerant).



## FRAME

Advanced technology, full butt-welded box sectional ladder-type frame with integral ROPS supports, integral front bumper, rear tubular cross members, steel castings at all critical stress transition zones, rugged continuous horsecollar.

Plate material	482.6 MPa <b>70,000 psi</b> tensile strength steel
Casting material	620.5 MPa <b>90,000 psi</b> tensile strength steel
Rail width	305 mm <b>12"</b>
Rail depth (minimum)	864 mm <b>34"</b>
Top and bottom plate thickness	45 mm <b>1.77"</b>
Side plate thickness	25 mm <b>0.98"</b> Rear
	32 mm <b>1.26"</b> Front
Drive axle mounting	Pin and spherical bushing
Drive axle alignment	Swing link between frame and axle



## BRAKING SYSTEM

Service brakes: oil-cooled, hydraulic-actuated, multiple disc brakes at each wheel. Traction system wheel slip/slide control.

Max. service apply pressure	18960 kPa <b>2750 psi</b>
Total friction area per brake	103729 cm <sup>2</sup> <b>16,078 in<sup>2</sup></b>
Secondary brakes	Automatically applied prior to hydraulic system pressure dropping below level required to meet secondary stopping requirements.
Wheel brake locks	Switch activated
Parking brakes	Multiple disc, spring-applied, hydraulically-released, dry brakes on inboard end of each wheel motor rotor shaft. Rated to hold on ±15% grade at maximum gross vehicle weight.
Electric dynamic retarder	Continuous 4476 kW <b>6000 hp</b>
Continuously rated high-density blown grids w/retard capacity at low speeds and retard in reverse propulsion.	



## SUSPENSION

Variable rate hydro-pneumatic with integral rebound control

Max. front stroke	328 mm <b>12.92"</b>
Max. rear stroke	239 mm <b>9.40"</b>
Max. rear axle oscillation	±6.5°



## COOLING SYSTEM

L&M radiator assembly, split-flow, with deaerator-type top tank.

Radiator frontal area	7.02 m <sup>2</sup> <b>75.5 ft<sup>2</sup></b>
-----------------------	--



## SERVICE CAPACITIES

Cooling System	719 L <b>190 U.S. gal</b>
Crankcase*	341 L <b>90 U.S. gal</b>
Hydraulic system	1325 L <b>350 U.S. gal</b>
Motor gear box (each)	95 L <b>25 U.S. gal</b>
Fuel	5300 L <b>1400 U.S. gal</b>

\* Includes lube oil filters



**DIMENSIONS**

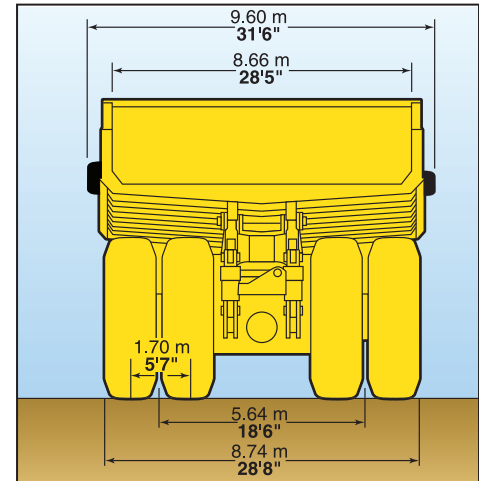
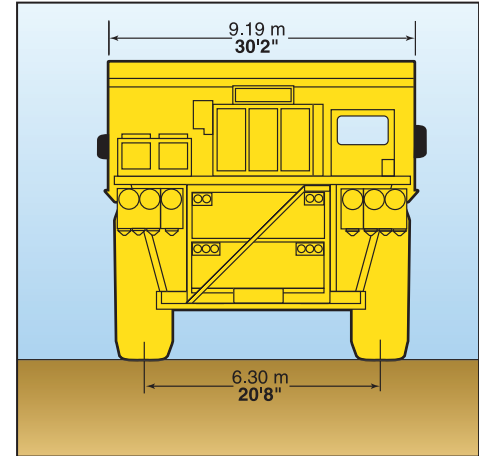
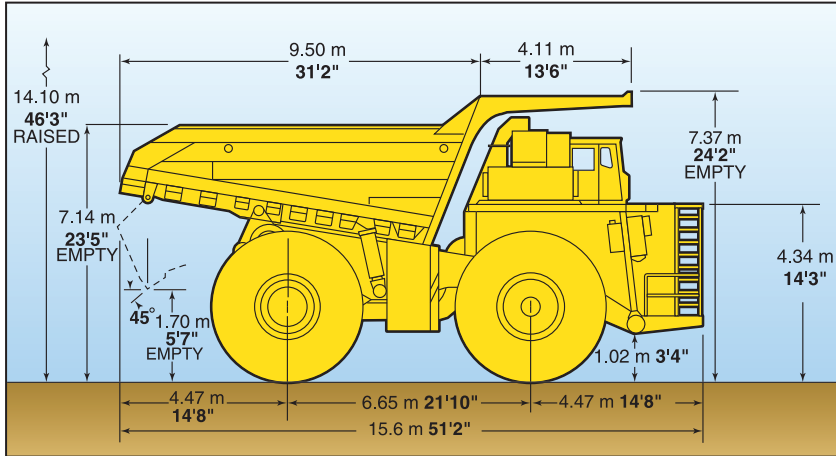

All dimensions are with standard body.

Body	Capacity		Loading Height*
	Struck	2:1 Heap	
Standard	149 m <sup>3</sup> 195 yd <sup>3</sup>	214 m <sup>3</sup> 280 yd <sup>3</sup>	7.14 m 23'5"

\*Exact load height may vary due to tire make, type, and inflation pressure.



**HYDRAULIC SYSTEM**

- Steering . . . . Accumulator assisted with twin double acting cylinders provide constant rate steering. Secondary steering automatically supplied by accumulator.
- Turning circle diameter (SAE) . . . . . 32 m 105'
- Reservoir . . . . . 947 L 250 U.S. gal
- Filtration . . . . . In-line replaceable elements
- Suction . . . . . Single, full flow, 100 mesh
- Hoist and steering . . . . . Dual, in-line, high pressure
- Brake component cabinet . . . . . Above deck, easily accessible with diagnostic test connections
- Hoist . . . . . Two 3-stage dual-acting outboard cylinders, internal cushion valve, over-center dampening
- Hoist times
  - Power-up loaded . . . . . 24 sec
  - Power-down . . . . . 24 sec
  - Float-down empty . . . . . 28 sec
- Pumps . . . . . Two pumps, single package, end of alternator
  - Hoist and brake cooling . . . . . Tandem gear pump with output of 931 lpm 246 gpm at 1900 rpm and 18960 kPa 2,750 psi
  - Steering and brake . . . . . Pressure-compensating piston pump with output of 246 lpm 65 gpm at 1900 rpm and 20685 kPa 3,000 psi
- System relief pressures
  - Hoist and brake cooling . . . . . 17237 kPa 2,500 psi
  - Steering and brake . . . . . 20685 kPa 3,000 psi
- Quick disconnects standard for powering disabled truck and for systems diagnostics.



**ELECTRICAL SYSTEM**

- 4 x 8D 1450 CCA, 12 volt, in series/parallel, 220-ampere-hour batteries, bumper-mounted with disconnect switch.
- Alternator . . . . . 24 volt, 140 amp
- Lighting . . . . . 24 volt
- Cranking motors . . . . . Two/24 volt

# 960E-1 ELECTRIC DRIVE TRUCK

## PERFORMANCE CHART

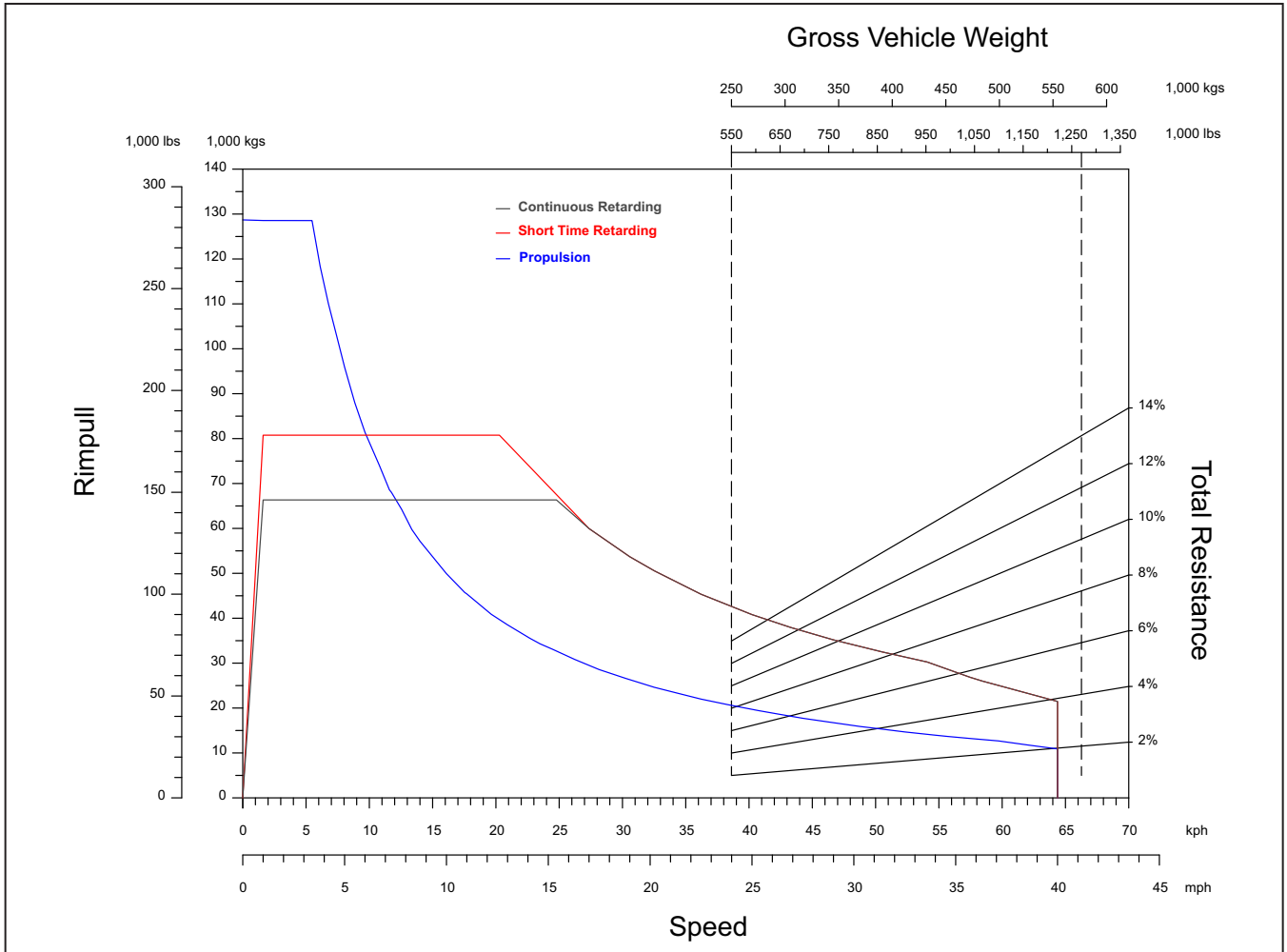

Short Time Retarding - While thermal conditions permit, short time retarding performance will be utilized.

## KOMATSU PRODUCT LINE LOADER/TRUCK MATCHING

### Typical Number of Passes to Load

		KOMATSU TRUCKS							
		HD785 100 ton	HD1500 150 ton	730E 200 ton	830E AC 245 ton	830E 245 ton	930E-3 320 ton	930E SE 320 ton	960E 360 ton
KOMATSU EXCAVATORS	PC2000 15.7 yd <sup>3</sup>	4	7						
	PC3000 19.5 yd <sup>3</sup>	4	6	7					
	PC4000 29 yd <sup>3</sup>	3	4	5	6	6			
	PC5500 37 yd <sup>3</sup>		3	4	5	5	6	6	7
	PC8000 55 yd <sup>3</sup>				3	3	4	4	5

Nominal truck payload rating (short tons)

Excavator bucket rating is based on 1780 kg/lcm **3000 lbs/lcy** material density.

**Empty Vehicle Weight**

Front Axle Distribution	123490 kg	<b>272,250 lbs</b>	49.5%
Rear Axle Distribution	125985 kg	<b>277,750 lbs</b>	50.5%
Total EVW	249475 kg	<b>550,000 lbs</b>	

**Gross Vehicle Weight**

Front Axle Distribution	190104 kg	<b>419,100 lbs</b>	33.0%
Rear Axle Distribution	385968 kg	<b>850,900 lbs</b>	67.0%
Nominal GVW	576072 kg	<b>1,270,000 lbs</b>	

**Payload**

Nominal Payload	326585 kg	<b>720,000 lbs</b>	
	327 metric tons	<b>360 short tons</b>	

Nominal payload is defined by Komatsu America Corp's payload policy documentation. In general, the nominal payload must be adjusted for the specific vehicle configuration and site application. The figures above are provided for basic product description purposes. Please contact your Komatsu distributor for specific application requirements.





## STANDARD EQUIPMENT

- Air cleaners, Donaldson® SRG
- Alternator (24 volt/140A)
- Auto lubrication system w/ground level fill & level indicator
- Batteries—4 x 8D (1450 CCA's)
- Battery charging cable and socket
- Body over center device
- Brakes: oil-cooled, multiple disc front & rear
- Control cabinet
- Electric start
- Eliminator, Centinel, Cense
- Filters, high pressure hydraulic
- Gate valves on hydraulic tank
- Ground level radiator fill
- Mirrors, LH flat and RH rectangular convex
- Mud flaps
- Muffled exhaust—deck-mounted
- Power supply, 24 volt and 12 volt DC
- Quick disconnects (hoist and diagnostics)
- Radiator sight gauge
- Removable power module unit (radiator, engine, alternator, blower)
- Retard speed control
- Reverse retarding
- Thermostatic fan clutch
- Fast-fill fuel system (in tank and left side remote)
- Service center—LH
- Body impact plate

### OPERATOR ENVIRONMENT & CONTROL

- All hydraulic service brakes with emergency auto apply
- Battery disconnect switch
- Body up sling
- Brake lock and drive system interlock
- Circuit breakers, 24 volt
- Diagonal staircase across grille, L to R
- Dynamic retarding with continuous rated element grids
- Engine shutdown at ground level
- Hoist propulsion interlock

- Horns (electric—front and back-up)
- Integral ROPS/FOPS Cab Level 2
- Maintenance and power lockout
- Parking brakes with warning light & speed application protection
- Power steering w/auto secondary steering
- Protective deck handrails
- Pump driveline protector
- Radiator fan guard
- Seat belts 76 mm 3" retractable
- Skid-resistant coating on walkways

### STANDARD HIGH VISIBILITY DELUXE CAB

- AC drive interface display
- Actia Dash & Status Panel
  - Body up
  - Parking brake
  - Propulsion system not ready
  - No DC link voltage
  - High engine oil temp
  - No propel
  - Service brake applied
  - Wheel brake lock applied
  - Maintenance monitor
- Air cleaner vacuum gauges
- Air conditioner HFC-134A
- AM/FM radio with CD & MP3
- Column-mounted retarder control
- Digital tachometer and speedometer
- Dome light
- Engine hourmeter, oil pressure gauge, coolant temperature gauge, hydraulic oil temperature gauge
- Engine shutdown w/ "Smart Timer" delay
- Floor mat (double barrier)
- Fuel gauge in cab and on tank
- Fuel low level light and buzzer
- Gauges (w/backlight)
- Headlight switch
- Heater and defroster (heavy-duty)
- Heater switch
- High beam selector and indicator

- Horn (center of steering wheel)
- Indicator lights (blue)
  - Engine service
  - VHMS snapshot (IM)
- Insulation (Max R-Value)
- Komatsu Payload Meter III
- Operator seat, adjustable w/air suspension, lumbar support and arm rests
- Panel lighting (adjustable)
- Passenger seat, full size
- Power windows
- Pressurized cab air system w/fan on
- Single brake/retarder pedal
- Starter key switch
- Sunvisor (adjustable)
- Tilt & telescoping steering wheel
- VHMS with ORBCOMM
- Voltmeter (battery output)
- Windshield (tinted safety plate)
- Windshield wiper (dual) and washer (electric)

### LIGHTING

- Back-up lights—rear mount (2) halogen
- Back-up lights—R and L - deck mount (2) halogen
- Brake and retard lights on top of cab
- Clearance lights
- Control cabinet service light (LED)
- Dynamic retarding, rear (2) halogen
- Engine compartment service lights
- Fog lights (2) halogen
- Headlights (8) halogen
- Stairway lights
- Manual back-up light, switch and indicator
- Payload lights R and L (LED)
- Platform lights R, L and Center
- Stop & tail lights (2) (LED)
- Turn signals halogen
- Under-hood service lights



## OPTIONAL EQUIPMENT

Note: Optional equipment may change operating weight.

- Air filter evacuators
- Body Liners\*
- Dynamic retarding Whispergrids
- Fire extinguisher 9 kg 20 lb
- Heated body
- Hot start engine coolant (220V 2-2500W)
- Hot start engine oil (220V 2-600W)
- Hot start hydraulic oil
- Mufflers between frame rails
- Reversed access ladder, R to L
- Service center—RH
- Shutters (radiator)
- Special language decals
- Suspensions, cold weather

\*Available factory installed or non-installed. All other options and accessories listed are available factory installed only.

AESS647-00

©2008 Komatsu America Corp.

Printed in USA

D02(1.5M)C

02/08 (EV-1)

**KOMATSU**®